

Protection Circuit

F1, F2, U7 intent to meet GR1089 lightning test and power cross, alternatively PTC1, PTC2, and U2 intent to meet intra-building lightning and power cross test. (description for one channel only)

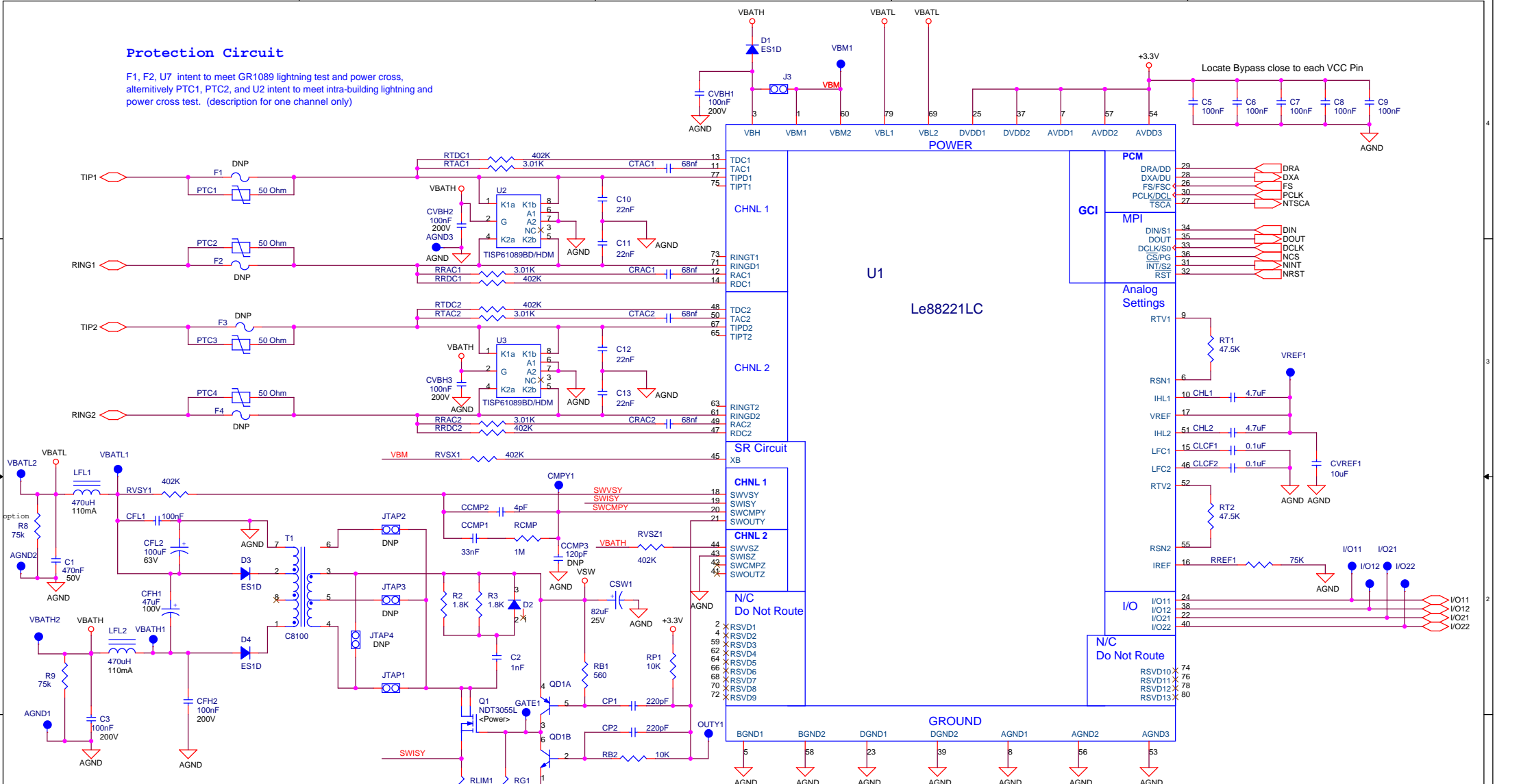

JTAP Configuration	
Use a hook-up for 0 Ohm connection	
VSW 12V Use C8100 for T1	VSW 5V Use C8102 for T1
JTAP1 = 0 Ohm	JTAP1 = Open
JTAP2 = Open	JTAP2 = 0 Ohm
JTAP3 = Open	JTAP3 = 0 Ohm
JTAP4 = Open	JTAP4 = 0 Ohm

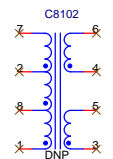

Title Le88221 example circuit			
Size Custom	Document Number Designed : Leming / Modified : Raymond AuYeung	Designer	Rev B
Date: Wednesday, July 20, 2005	Sheet 1 of 1		